

MAINE

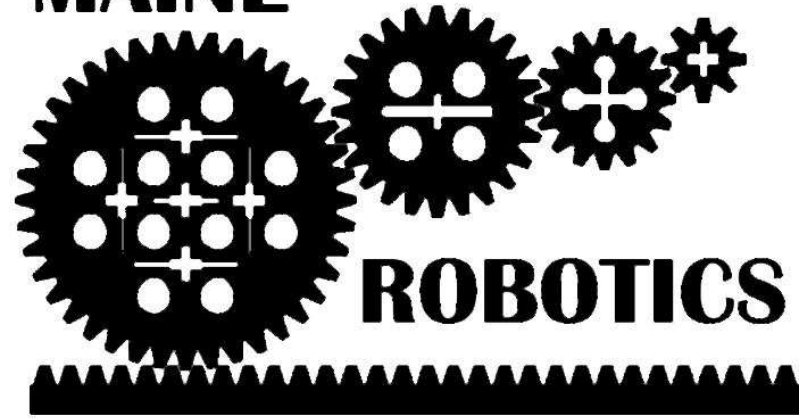

Our 5th Year!!

2009 Maine Robot Track Meet

Note changes from previous years

Sponsored by Maine Robotics

Director: Tom Bickford

www.mainerobotics.org/trackmeet.html

Dates:

- May 2nd, 2009 – Auburn Middle School
- May 9th, 2009 – Maine Maritime Academy
- All registered teams will be kept apprised of any date and/or location changes
- All information will be posted on the website:
www.mainerobotics.org/trackmeet.html

2009 Maine Robot Track Meet

- Slope Climber
- Table Clearing Mission (*new*)
- Delivery Mission (*changed*)
- Fastest Robot (*changed*)
- Strongest Robot
- Bridge Building
- Ping Pong Shot Put (*changed*)
- Robot Speed Build (*added NXT*)

Gold Standard

- Starting in 2009 we will be awarding ribbons for teams that can meet the Gold Standards set for different events!
 - Slope Climber: 60 degrees
 - Delivery Mission: Center Ring
 - Fastest Robot: 3.5 seconds
 - Bridge: 60 Pounds
 - Speed Build: 3.5 minutes
 - Ping Pong Shot Put: 20 points
 - Strongest: 40 pounds
 - Table Clearing: 8 cans

A few words about the Meet:

I used to run track as a youth, and I remember how each track at each school was different. Some were compacted ash tracks, others asphalt, others grass.

Each track meet would also be held in different weather. Once I remember running in the snow, some times it would be in the eighties, and sometimes in the rain.

The point being, each event was impossible to predict for. Those who trained in the rain did better in the rain. Those who trained on asphalt did better on asphalt. The robot track meet is no different. I could get old(er) trying to make every team and group play on exactly the same playing field and not achieve such a goal. Instead each team will have time to get “warmed up” and “acclimated” to the conditions at the meet. Plan to use this time to change your programs for light levels or conditions different from your home track.

Good luck, Tom Bickford
Director, Maine’s Robot Track Meet

Organization of Meet:

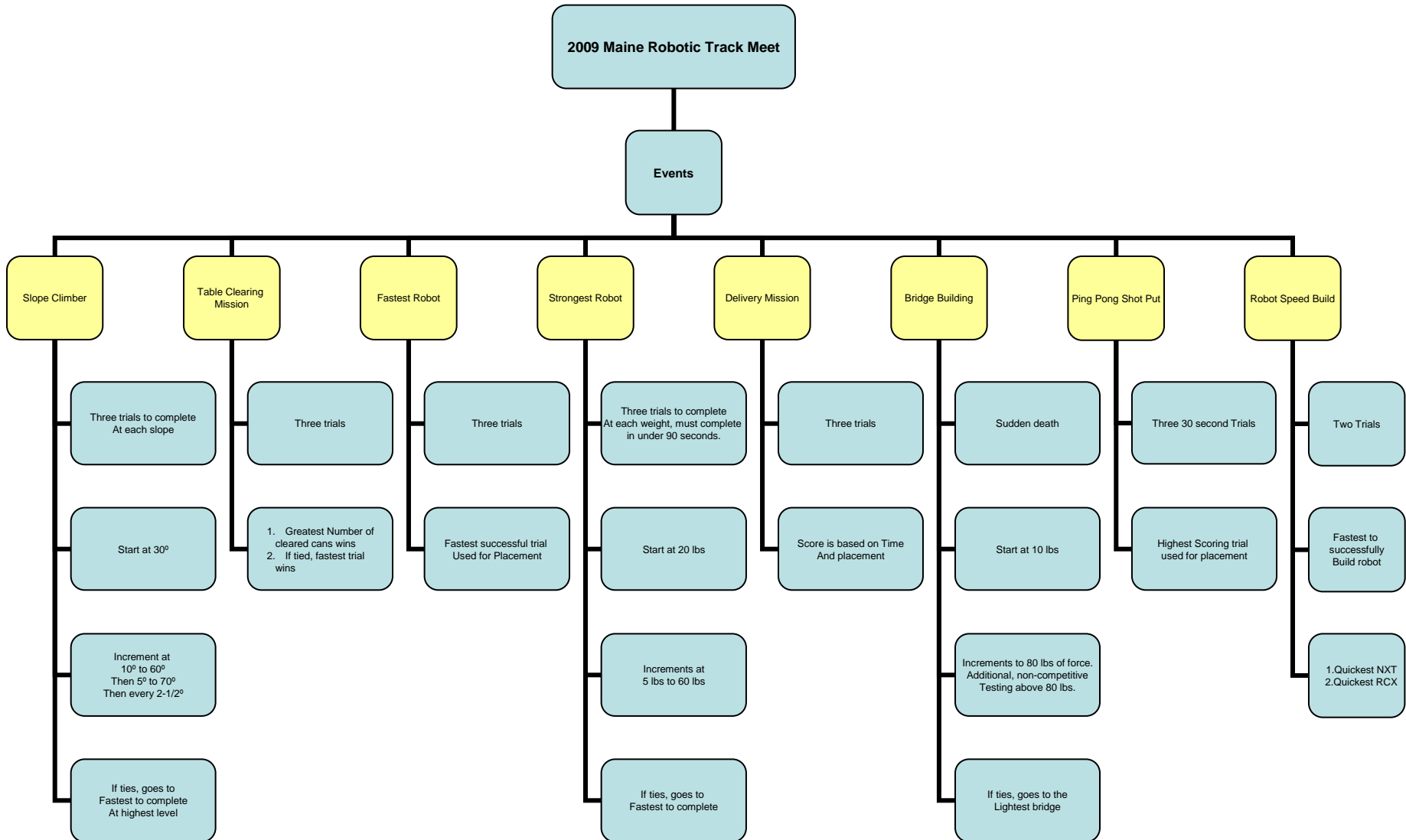

Volunteers:

- The Maine Robot Track meet is organized by Maine Robotics but depends on coaches and parents to volunteer on the day of the event to assist as timers and officials.
- Day-of-the-event training is available and each team should plan on recruiting at least one volunteer.

Scoring:

- Awards will be given to each team winning an event. If enough teams register for an event we will have 2nd and 3rd place awards as well.
- Trophies, medallions, or ribbons will be determined by the number of teams registered for the Meet.
- The overall winning team for the meet will be the one with the most points (Maximum possible overall score is 21 points – 7 events x 3 pts = 21 pts)
 - 3 points for first place
 - 2 points for second place
 - 1 point for third place
- In the case of ties for equivalent overall scores for the meet the winner will be determined by the number of
 - 1st places (or subsequently 2nd places, or 3rd places).
 - Each team will be acknowledged
- All participants will receive an event t-shirt.
- ***Some events will have “Gold” standards. If a team meets that level, it will receive recognition for meeting or exceeding that goal.***

Required from Teams

- Team Name
- Coach name(s) and contact information
 - Phone, email, address
- Event location attending
- Event's being entered, number of robots, RCX/NXT type
- Names of all team mates
- Registration payment
 - (\$30/team member) before April 6th, 2009
 - (\$35/team member) on or after April 6th, 2009
- Signed and returned release forms for all participants

Basic Guidelines:

- A team may compete by registering for one, several, or up to 7 events.
- A team is not limited in size.
- All members of the teams must be currently enrolled in grades 3 to 8.
- All members must have a signed consent and release form to participate in the track meet.
- Local teams may be organized as part of a schools curriculum, after school program, a home school program, a community activities program, a neighborhood/family group, or any other group providing the team is coached by an adult over 18 years of age who is acceptable to the parents/school/group in their own community.
- The Maine Robot Track Meet is designed to evaluate finished products in the form of robot performance or LEGO structural design.
 - In this respect it is very much like a track meet.
 - Robots may be of any shape or variety as long as they meet the robot rules outlined in that events section.
 - Programs, individual building styles, team work, or other important aspects are NOT part of the Track Meet. All criteria are based on the ability of the robot to perform under specific challenges.
 - However, it is required that the work and programming of the robots be done by the students. Mentoring is allowed by adults, but ownership of the building and programming is expected to remain with the team members. When in doubt, demonstration of this ownership may be required.

Entering Events:

- Each team may enter 7 events
 - Examples:
 - One robot in 7 different events
 - Seven different robots in the same event
 - 3 robots, 2 in the fastest, 1 in the strongest
 - 2 robots, 2 in the fastest, plus a bridge
 - 3 bridges, 4 robots
 - Any combination as long as no robot/bridge is entered in the same event more than once and that the total entries is less than or equal to 7.
 - Having a robot entered in more than 1 event may result in scheduling conflicts at the meet. While we attempt to accommodate, the meet schedule will not be changed to make this possible. Strongest and slope climbers typically take a long time and these robots should not be entered into other events.

Robot Rules:

- All robots and structures must be made entirely of LEGO materials.
- Each robot may contain only a single RCX or NXT unit.
- A team/school/group may bring more than one robot.
 - Most events will not have compatible robots. For example a robot that is the fastest will not likely be able to compete as the strongest.
- The robot must be a single unit; connected by hard LEGOs (not wires, elastics, or string).
 - However, joints, swivels, or other mobile parts are allowable.
 - Projectiles, launchers, tethers, or remote units are not allowed. When in doubt, build a better robot, not a better gizmo. With the exception of the Ping Pong Shot Put in which case the ping pong balls must, by the nature of the event, leave the robot.
- The number of motors and sensors allowed is not dictated. However, all motors and sensors must be unaltered from their original LEGO state.
- Robots may not be altered between heats to obtain better results, broken or damaged robots may be repaired.
 - For example: A robot that can go up a 60 degree slope must also be able to go up the 20 degree slope. A robot capable of pulling 40 pounds, must also be able to pull the 10 pounds.
- Robots must start behind, or within their respective starting spaces. For those with finish lines, the robot is said to have crossed the finish line as soon as any part of the robot body has passed the finish line.
 - The part of the robot directly behind the starting line is generally considered to be the part that needs to cross the finish line. Arms or other devices designed to extend beyond the robot after starting are not considered to be part of the robot body.
- No robot may employ extending arms or devices that are activated after start in order to extend the "reach" of the robot and hence to cross the finish line earlier. The robot is considered to cross the finish line when the robot body (that which was behind the start line) crosses the finish line.
- For the Ping Pong Shot Put, see details under that specific event for allowable arms, parts, and strategies.
- **Robots must have a built in delay of at least one (1) second between pushing the run button and the robot commencing operation, see figure at bottom of page. All times are measured from the time the robot crosses the start line (or leaves the start box). This time must be used by team members to remove all hands from the vicinity of the robot.**
- No glue, adhesive, or non-LEGO parts may be used in the building of the robot.
- No AC power adapters may be used on the robot.
- External 9 Volt (LEGO) power supplies may **NOT** be used on the robot (New in 2007)
- Batteries and power used may not exceed 1.5 volts per battery or 9 volts total. Winning robots may be required to submit their robot for evaluation of battery supply.
- LEGO weights are allowed
- No communications is allowed between the team and the robot
 - No IR Tower or Bluetooth communication
 - No RCX/NXT to RCX/NXT communication
 - No LEGO (or other) Remote control devices
- Each event will specify if it requires the use of sensors. If an event requires the use of sensors and they are not used, or not evident in their use, the officials may require a demonstration of the use of said sensors and disqualify if it becomes apparent that a robot is operating by dead-reckoning in an event that requires sensor feedback.

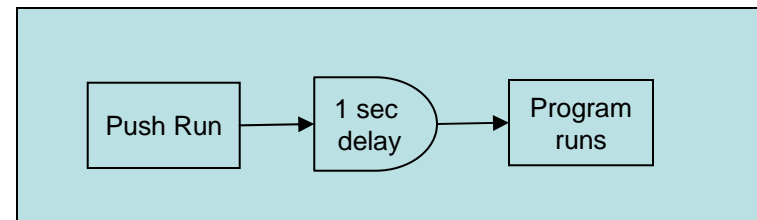

Event 1: Slope Climber

- The slope climber event is designed to focus on the following:
 - Center of gravity
 - If your group doesn't understand this it will not be able to make a successful robot to climb the slope
 - Adaptability (must work at all elevations)
 - Friction (what works best to increase friction between the track and the robot)
 - Also cover static versus kinetic friction and which do they want?
 - Relationship between friction and applied pressure (in this case weight from the mass of the robot in Earth's gravitational field)
 - Gear ratios
 - How do you obtain the speed and control that is needed?
 - Speed and stability
 - What characteristics are most important in a robot that can successfully perform this challenge

Event 1: Slope Climber

- Center of Gravity (cg)
 - For an object to be at equilibrium and stable it must be at rest with the center of gravity directly below the point of support (so no car is really stable since the CG is always above the tires). However, an object can be at equilibrium and still be unstable. This is what you will be attempting to achieve in this exercise. To do this the CG must fall between the supports of the object (or robot in this case)
 - Since the RCX/NXT is the largest contribution to weight for most robots, it is important to consider where it will be placed in the robot.
 - Example A: Gravity places the weight of the robot on all of the wheels (between points of support)
 - Example B: This is showing maximum angle for the robot to still have weight being placed between the points of support (reality would likely cause this robot to fall due to instabilities)
 - Example C: Shows a robot that will fall backwards over its rear wheel because the point of supports are not beneath the cg.
 - Experimentation to provide a **cg** that is between the wheels or supports will be necessary.

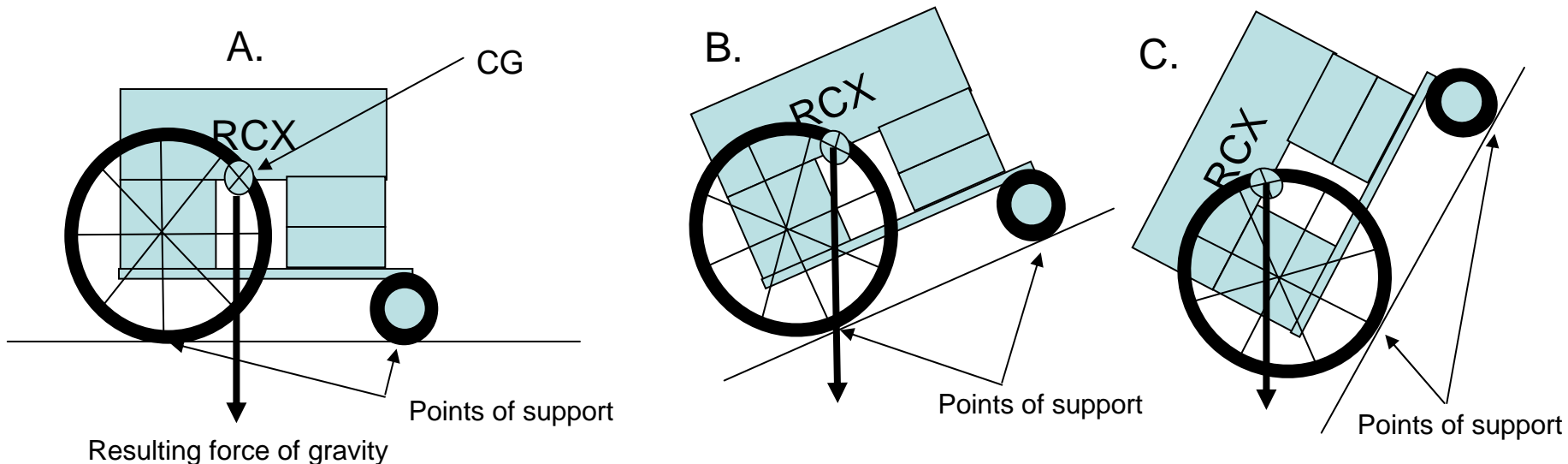

Checking Center of Gravity (cg)

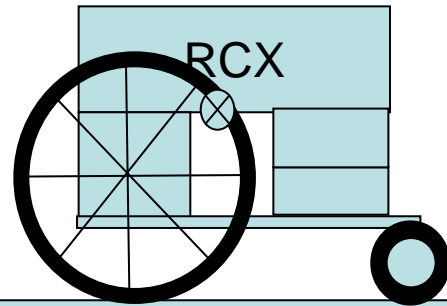

Place the robot on the center of a piece of foam board Or other rigid but light weight material. Move a supporting wedge or roller Forward or back until the robot and board Are “balanced” on the support. This will indicate The approximate front to back cg.

Now move the support so the robot and board Are resting on the length axis rather than the Width axis. Adjust until the board and robot Are again balanced on the support. This will Be approximately below the side to side cg.

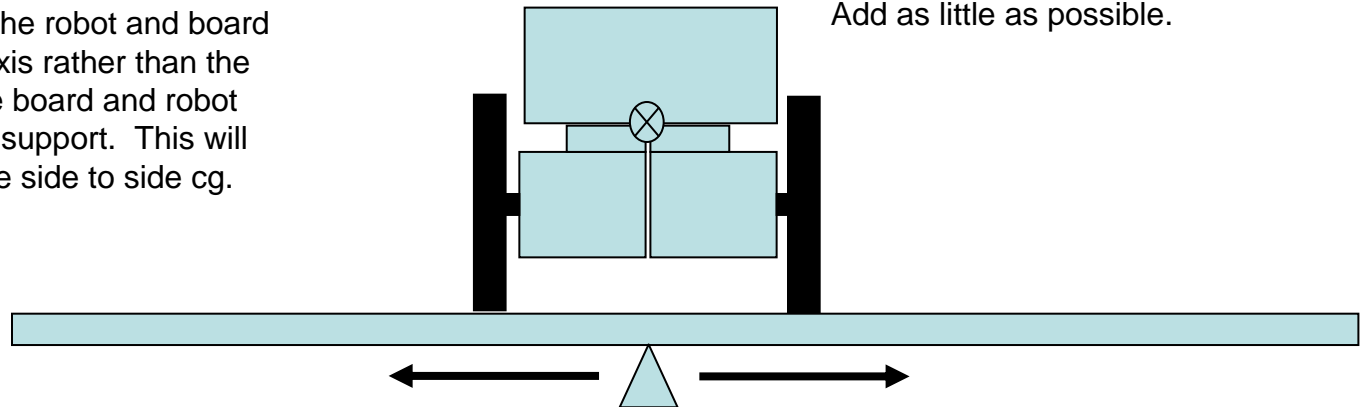

You may have to use small pieces Of tape or other material to keep the Robot from rolling. Remember that Whatever you add will affect the cg, so Add as little as possible.

Event 1: Slope Climber

Climbing Competition:

Similar to a high jump competition

In that you continue to “raise the bar”

Until robots are eliminated.

- Platform is 24 knobs wide
- Platform is 132 knobs long
- Platform starts at a **30° slope**
- Slope will increase to 60° in 10° increments.
- Slope will increase to 70° in 5° increments.
- Slope will increase to 85° in 2½° increments
- **<<Clarified>> Robot may touch the sides, but may not clamp, grapple, or use opposing devices to gain support from the walls of the climbing platform.**
- If robots tie for highest angle climbed, ties will be decided by fastest to make climb
- Robot must work at all subsequent elevations to proceed. No modifications allowed between elevations **other than for weight distribution** (can move weights or RCX/NXT around for better cg).
- Platform is bounded by 1”x4” (nominal) lumber to provide lateral and end barriers
- Inner dimension of platform is 37½ inches long and 7½ inches wide and covered with LEGO plates (built to accommodate plates, not lumber dimensions).

NOTE: The ultimate security of the robot is the responsibility of the team. If a Robot is starting to fall or slip Uncontrollable, it will be up to the team To “save” the robot from falling off and Damaging itself.

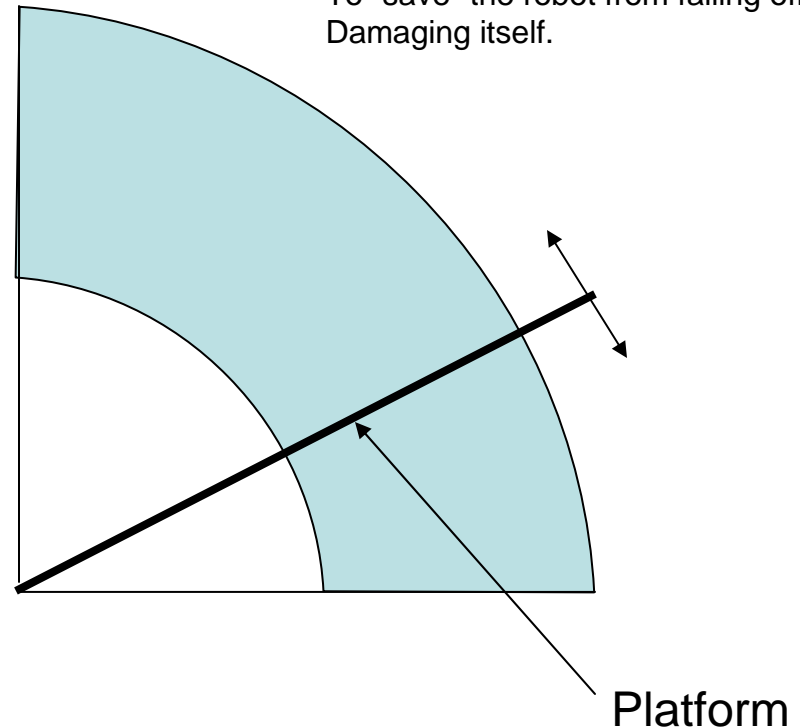

Event 1: Slope Climber

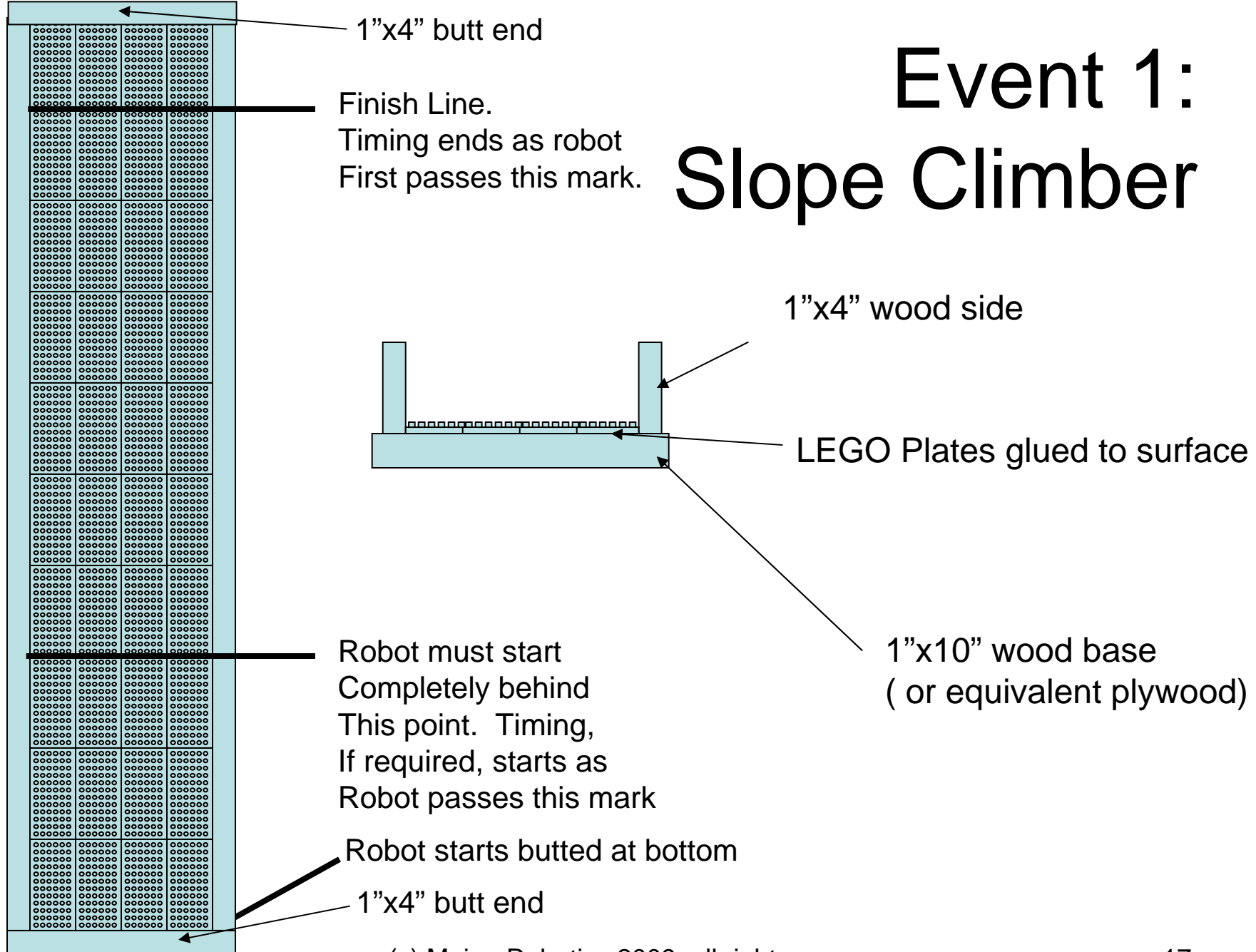

Event 1: Slope Climber



Inclinometer may
Be helpful and available
From local building supply
This one is ~\$13

NOTE: Any appropriate means
Of holding the platform up at the
Correct angles is acceptable.

NOTE: Hanger bolts
have a wood screw end
and a bolt end. This
allows them to be driven
into the base (wood) and
have a wing nut on the
other end.

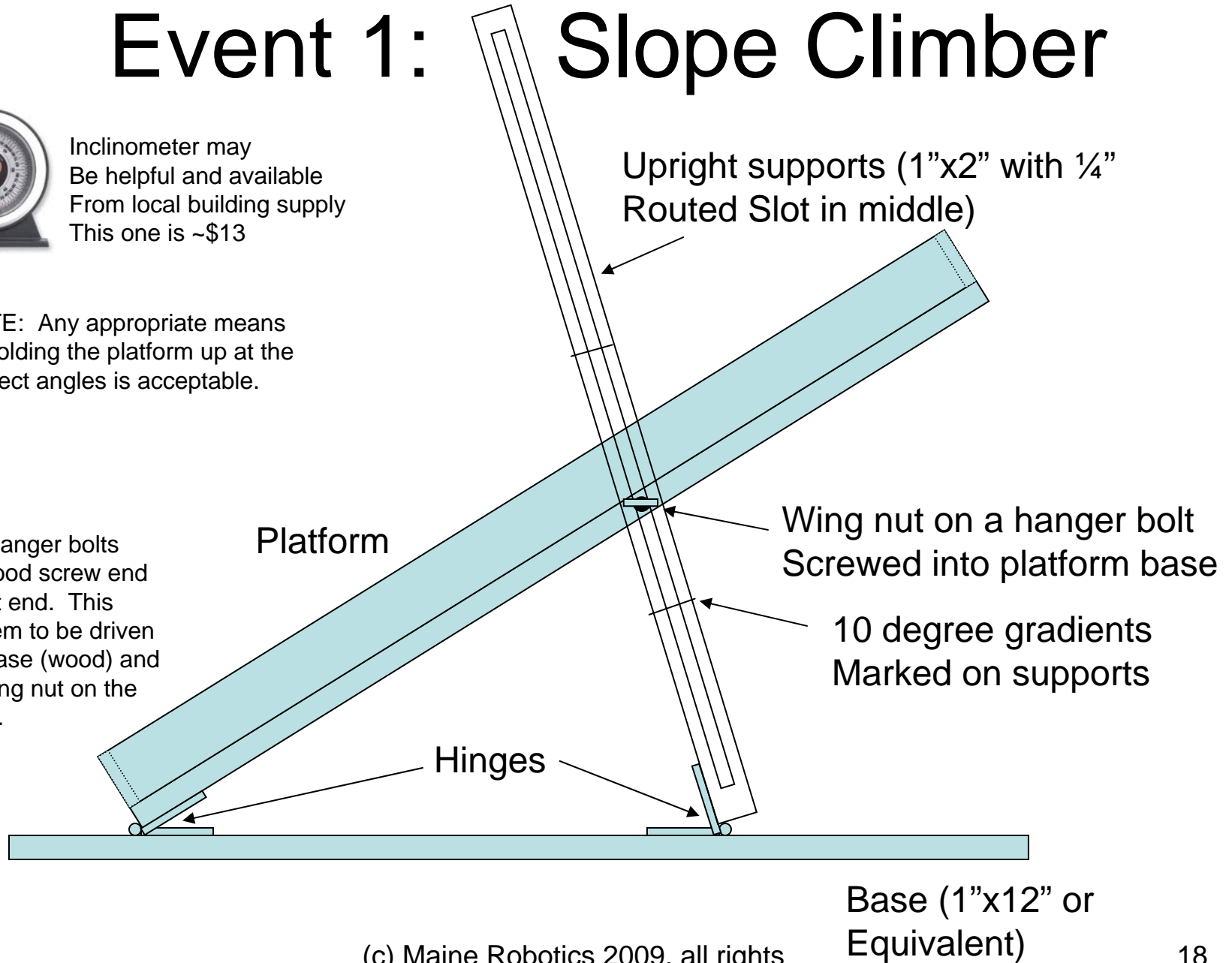

Event 1: Slope Climber

An alternative bolt system:

This is easier to make, however
Note that the carriage bolt head
Projects into the robot area of
The slope.

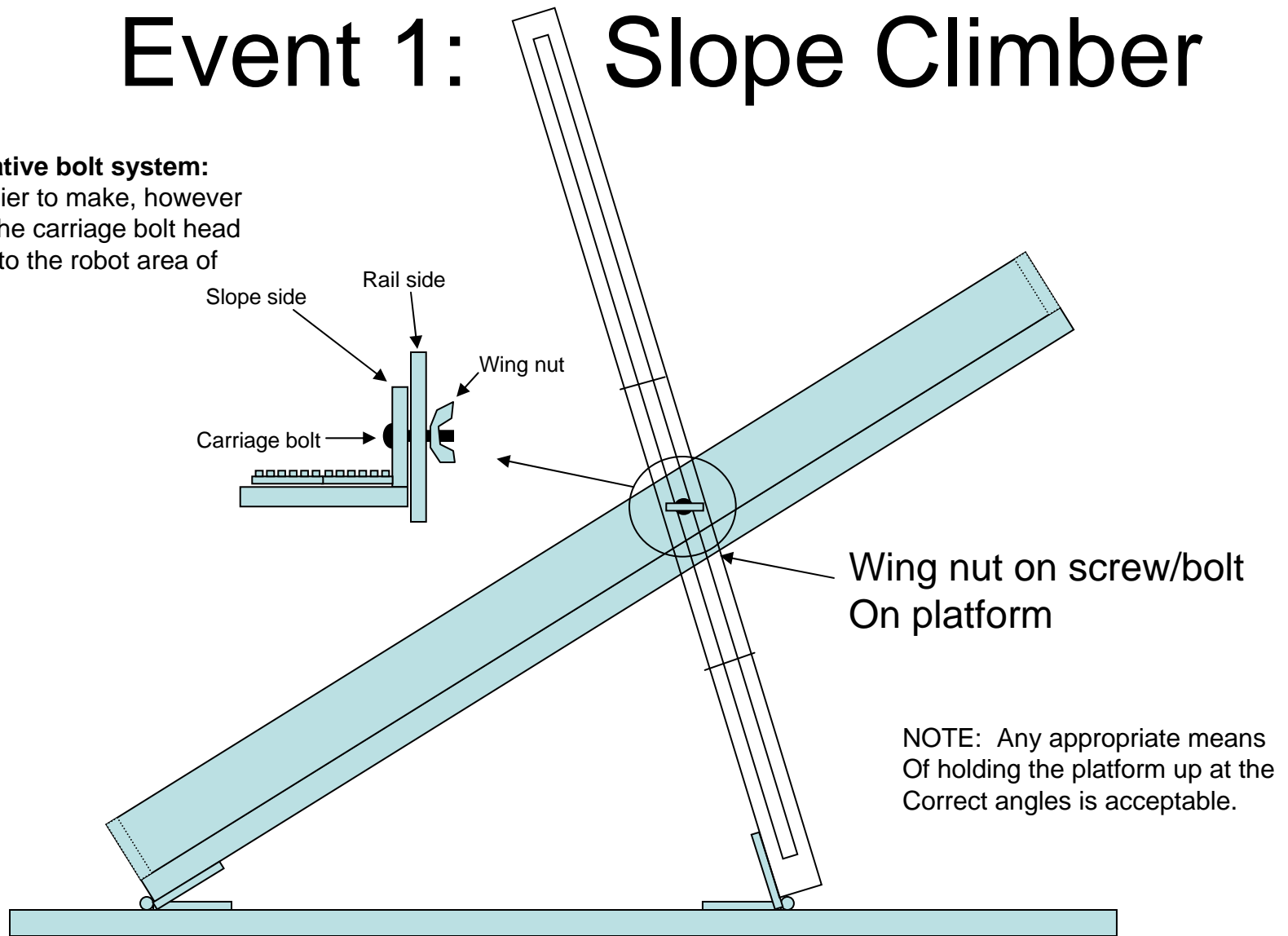

NEW!

Event 2: Table Clearing Mission

- Robot must navigate a table top surface without falling off
- Robot must attempt to clear all 8 empty cans from the top of the table surface
 - Cans will be empty 12 ounce aluminum soda/juice cans
 - Placement will be noted at the competition (stays the same for the day)
 - 4 will be right of center and 4 will be left of center
 - 4 will be above midline and 4 will be below midline
- Sensors **must be incorporated** to perform this task
 - Robots that rely only on dead reckoning will not be qualified to perform in this event.
- Table top is 4' long and 3' wide
- Table top is white and has a 90 degree edge
 - **New in 2007: The corners will be trimmed by cutting 6" x 6" triangles off each of the 4 corners.**
- There are no borders or markings on the table top except for
 - A 12" square set in the center of the table
 - Square is made with a thin tipped permanent marker
- Robot must be started completely within the starter square
 - No extensions beyond the starting robot shape are allowed.
 - No extensions allowed after the start of the robot (what it starts as is how it should end)
 - Any moving parts must not exceed the total 12" x 12" maximum size allowance.
- Robot must navigate around the table without falling off or becoming stuck
- Each robot will have 3 trials to remove the greatest number of cans from the table surface. The highest score/time will be used for its ranking.
- Highest score goes to the greatest number of cans removed.
- If a tie exists as to the number of cans removed, then the following will be used for tie breaking
 - the highest total for the 3 trials will be used
 - The quickest – highest scoring trial
- **A maximum of 90 seconds per trial is allowed.**
- If human intervention is required due to a robot being stuck or in danger of falling off, the robot is disqualified for that heat.

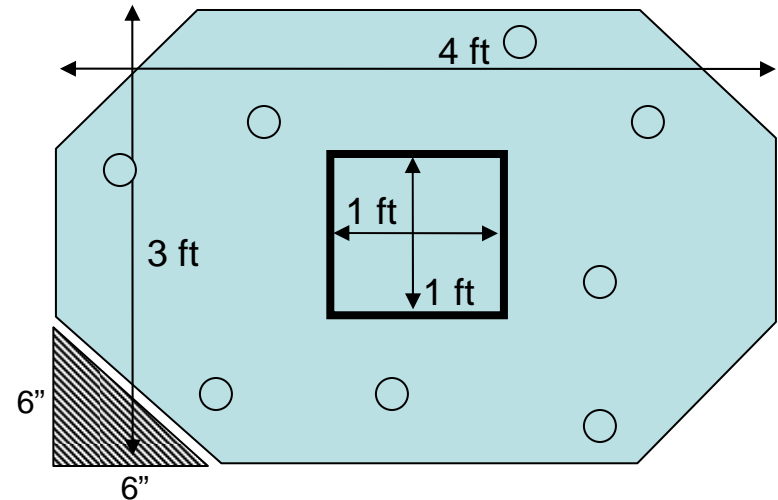

Light, touch, and ultrasonic sensors would be suitable sensors
To stay on the field.

Use of either a grid-clearing program or use of ultrasonic
Sensors would likely be the best options for clearing the cans.

NEW!

Event 2: Table Clearing Mission

- Table construction may be made any way to meet the requirements.
 - The ones at the finals shall be made of $\frac{3}{4}$ " melamine with edges cut but not finished
 - The middle square will be measured to be a 1 foot square, perpendicular to the sides and equidistant from the two sides and top/bottom respectively (1 $\frac{1}{2}$ feet from each side, and 1 foot from the top and bottom)
 - Each of the four corners need to have a 6" x 6" triangle trimmed off the corners.
- Other means to construct easy tables would be to use melamine surfaced shelves commonly available at building supply and department stores. Three 4' long shelves can be attached together on the bottom with stringers and the cracks (if they impede the robot) covered with white or tan tape)
 - Note: a 12" wide shelf is often less than 12". This event assumes that since the robot is using sensors to interpret its environment that this should not be a problem.
- If a robot depended only on touch or rotational sensors it would not matter what color a groups table was, only that it was of the appropriate size.
- Since each table may be different, and lighting conditions variable, each group must be prepared to adapt their robot and program to the circumstances of the match.

NEW!

Event 2: Table Clearing Mission

- At the local mega hardware store 12" x 96" white shelves were listed at around \$12
- At the same store a sheet of 3/4" melamine (49" x 97") was listed at around \$30 and would be enough for making all of the items needed for the track meet.
- So depending on your carpentry skills you may want to cut a larger piece down, or screw three smaller ones together.
- Remember, since this requires the use of sensors, there should be no reason the robot cannot accommodate a table that is not EXACTLY 36" x 48"
- Rough cut Melamine will have a rough particle board type edge while using shelves have a finished, laminate edge (depending on type of shelves purchased). This could make a difference to your robot. Again the ones at the meet will not have laminate edges.

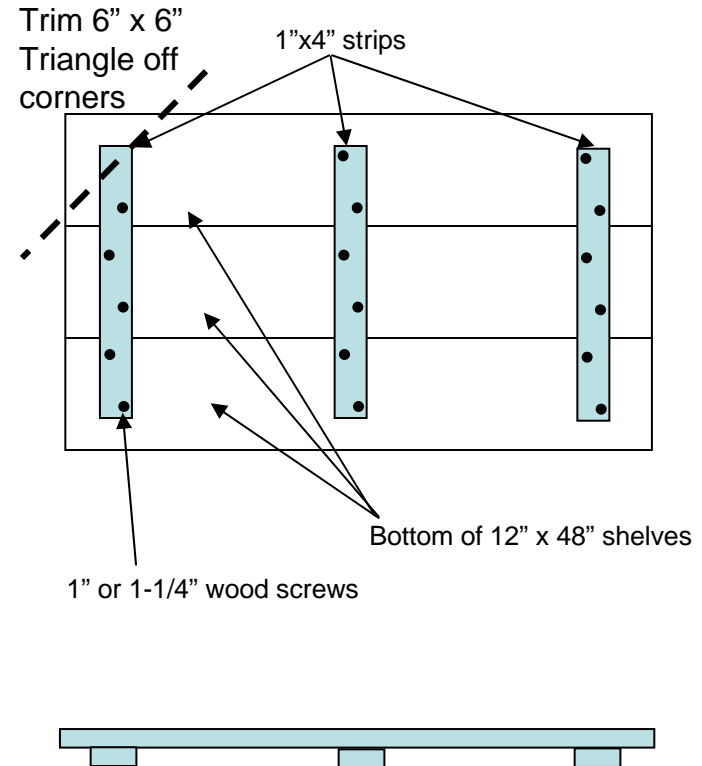

Changed!

Event 3: Delivery Mission

- This event is designed for both building and programming skills!
- Robot will **carry** the LEGO® object and deliver it to the target at the other end of the course.
- The robot must **carry** the object and then leave the item in order to score.
- The robot may not throw or otherwise deliver the object.
- The score is based on the time for delivery and the placement on the target.
- Placement on the target: Any portion of the object over a boundary line qualifies the placement for the higher scoring area.

Event 3: Delivery Mission: Layout

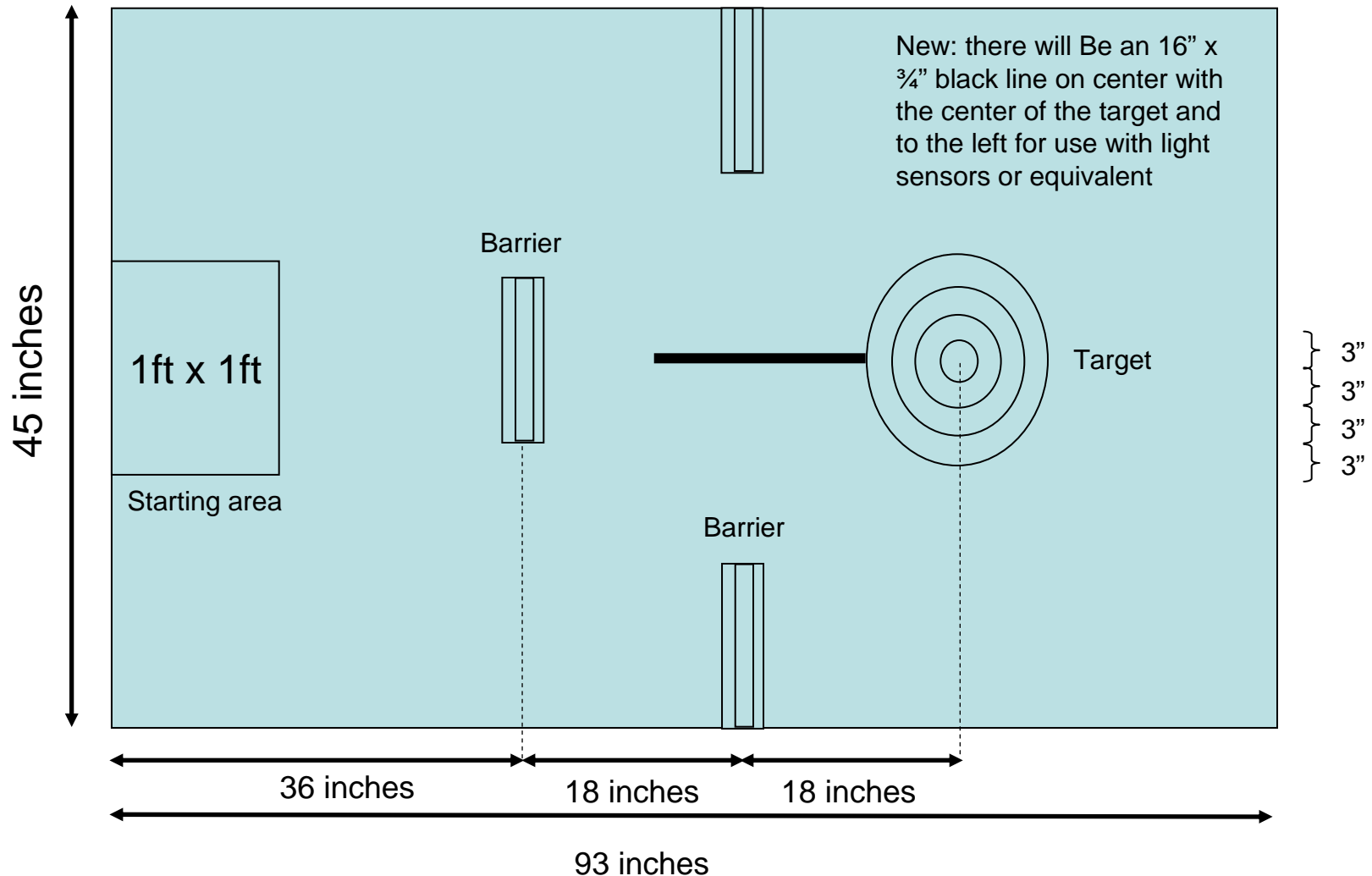

The dimensions (45x93 inches) are based on
The size of a FIRST LEGO League mat or table.
Just thought you would like to know why the odd size.

(c) Maine Robotics 2009, all rights reserved

Event 3: Delivery Mission: Scoring

- Qualification:
 - Object is **carried** by robot to target
 - Object is placed/dropped on the target
 - Robot finishes completely **off** the target
 - Barriers are in their original position
- Time:
 - Time from leaving the start box to leaving the target after leaving the Object
- Bonus:
 - Subtract 6 seconds for object delivered to the inner ring
 - Subtract 4 seconds for object delivered to the second ring
 - Subtract 2 seconds for object delivered to the third ring
 - Subtract 0 seconds for object delivered to the outer ring

Event 3: Delivery Mission: The Object

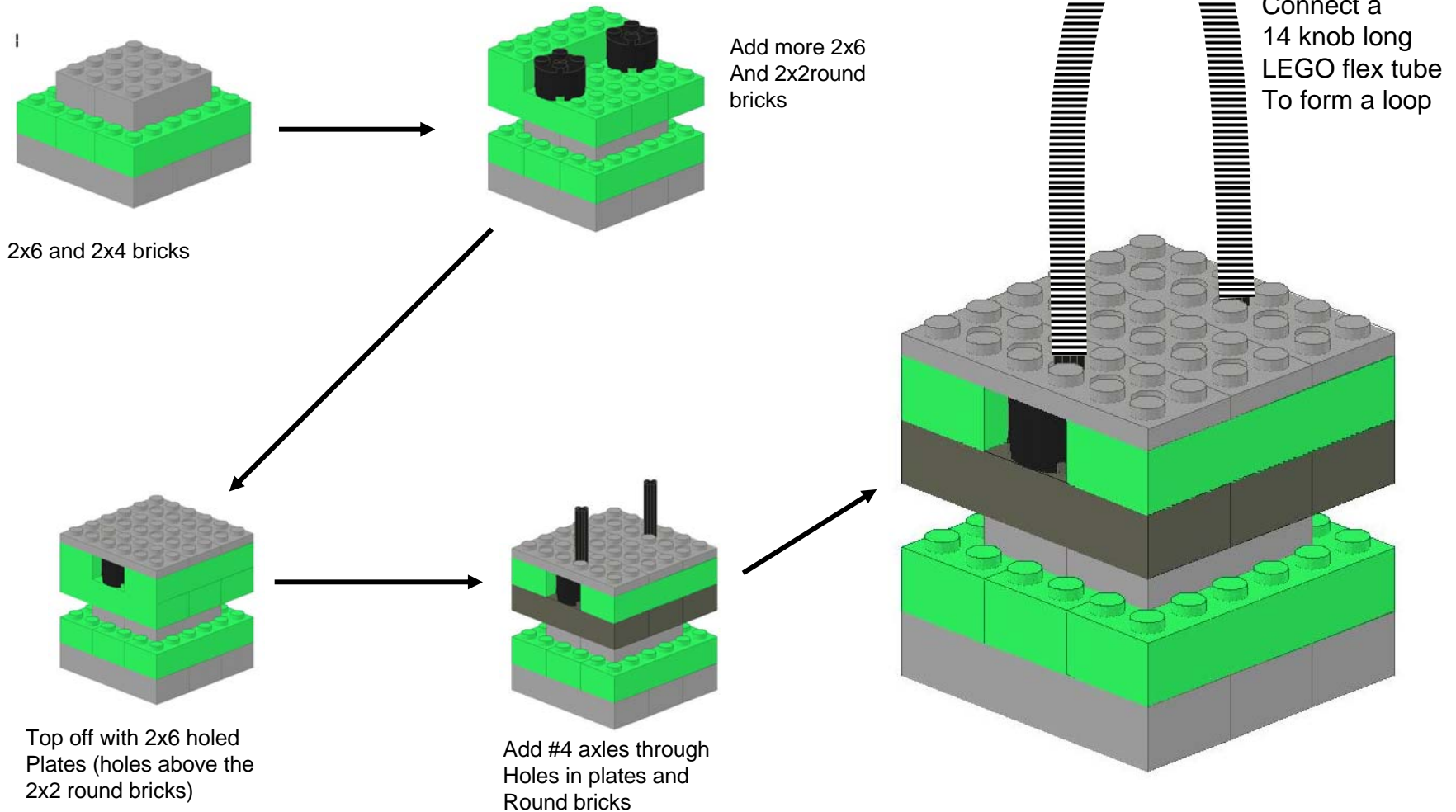

Event 3: Delivery Mission: The Barriers

- Barrier walls will be made of 1"x6" nominal wood attached to 1"x2" bases.
- This will make for a barrier approximately 6-1/4" tall and a base 1-1/2" wide.
- Barrier will be 12" in length.

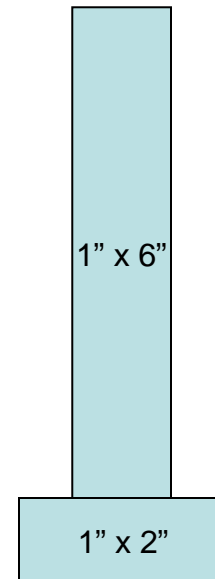

Changed!

Event 4: Fastest Robot

- This event is designed to see which robot can cover a set distance faster than any other robot
- The robot must transverse **18 feet** (new for 2009) of floor
 - Note: we are moving to metric when possible, but most school floors are still the 1 foot vinyl tiles, it is easier to measure out on the floor by feet.
- The robot must **pass between** two end pylons that are 4 feet apart at the end of the **18 feet**.
- Robots that dislodge the pylons are disqualified for that heat.
- There are no markings on the floor for use as reference.
- The starting line is a 1 foot long line, parallel to the finish line and **18 feet** away.
- The robot must start between the start and back lines (12")
- The robot that successfully completes the distance with accuracy and with the best time will be the winner.
- A robot is said to cross the finish line when any part of the robot body passes the finish line.
- No sensors are required for this event.

18 FEET!

Changed!

Event 4: Fastest Robot

- The fastest robot event is designed to focus on the following:
 - Relationship between the mass of the vehicle, the force generated, and the acceleration obtained.
 - Newton's three laws of motion
 - I. Every object in a state of uniform motion tends to remain in that state of motion unless an external force is applied to it.
 - II. The relationship between an object's mass m , its acceleration a , and the applied force F is $F = ma$. Acceleration and force are vectors (as indicated by their symbols being displayed in slant bold font); in this law the direction of the force vector is the same as the direction of the acceleration vector.
 - III. For every action there is an equal and opposite reaction.
 - What is the relationship between acceleration and velocity? Velocity and speed?
 - What is the relationship between mass and weight?
 - What is the relationship between force, power and work?
 - What about potential and kinetic energy?
 - What is energy?
 - <http://science.howstuffworks.com/fpte.htm> is a good site to learn more, although they have more ads each year.
- Gear ratios on the robot drive system
- Also consider:
 - Mass of the drive system
 - Power level of the batteries
 - Friction
 - Stability (must remain on course)
 - Robust design (shouldn't fall apart)

$$F=ma$$

F =force delivered by the motors and powered by the batteries.
 M =mass of the robot and all parts
 A =acceleration of the robot when the force is applied.

Changed!

Event 4: Fastest Robot, Cont.

- In 2008 many robots finished the 15 feet in 2.2 to 2.3 second time frame.
- Things to consider:
 - Adding motors increases the amount of force applied but also increases the mass of the object
 - In general, decreasing mass will increase acceleration
 - For these motors, force is directly related to the power level (in volts) of the batteries. So fully charged batteries = more force applied = greater acceleration
 - For these speeds air friction is considerably small in comparison to other forces; so barring having sails on the robot you can ignore air friction (air resistance)
 - We will have timers at the meet capable of measuring 1/100ths of seconds to eliminate the multitude of ties that occurred when we only measured to 1/10th of a second.
 - In the event of ties:
 - Best average of 3 trials will be used to break ties
 - Lightest robot will win if all times are equivalent.

Changed!

Event 4: Fastest Robot

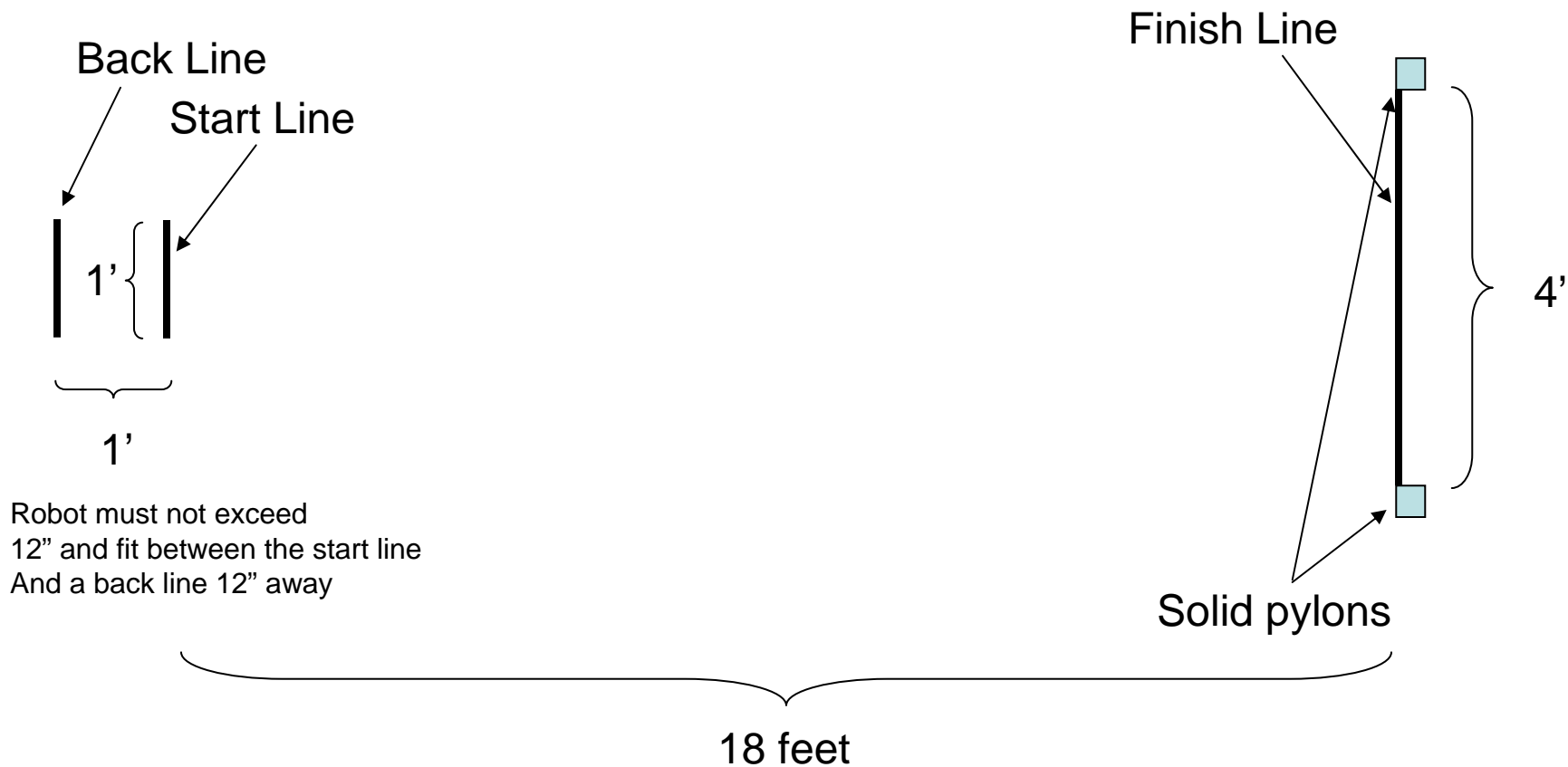

Event 5: Strongest Robot

- In this event the robot must pull a weighted wagon across 2 feet of floor.
- The wagon is not made entirely of LEGOs in order to make sure the wheels stay even and apply uniform conditions during the numerous heats required.
- The wagon will have a solid loop at 1-1/2 inches from the ground at the center front of the wagon for use in attaching to the robot. The Loop is NOT made of LEGOs but will have an inside diameter of at least 1-1/2 inches and will not be thicker than 3/8 of an inch.
- What a team uses for a wagon is immaterial except that an equivalent loop be provided at the same height for practice (our wagon uses non-ball bearing axles)
- The robot may only connect to the wagon at the loop and may only use LEGOs to make the connection.
- In this instance a connection refers to a point where the two are in contact rather than a connection as often used in reference to LEGO pieces that have been coupled with knobs and holes.
- Weight shall be added to the wagon with a starting weight of 20 pounds plus the weight of the wagon.
- **(NEW)** The weight will increase at 5 pound increments to **60 pounds** in an elimination competition.
- If more than one team can successfully pull 60 pounds over the two feet of course than those with the quickest time shall be the winners.
- Each robot may use as ballast any LEGO parts AND one or two 12 oz cans of SODA or JUICE in original and full condition. These must be attached with only LEGO parts and must be on the robot and completely off the ground. Use of such ballast is completely optional.
- The robot (not the pulled cart) must not exceed 12" in length, as measured between a "back line" and the "start line".
- Maximum time to transverse the 2 feet shall be **90 seconds**. Time for disqualification is measured from the time the robot starts until 90 seconds have passed. The qualifying time (used for time breaking) is based on the time from crossing the starting line to the time crossing the finish line.
- The official may call a trial (cancel) if the robot has veered off course or fails to start after a reasonable time has passed.
- **All robots regardless of the number of motors will be in the same class**

Event 5: Strongest Robot

- The Strongest Robot event is designed to focus on the following:
 - Newton's three laws of motion
 - The application of gear ratios
 - The relationship between mass, weight, and friction
 - Integrity of mechanical structures

Event 5: Strongest Robot

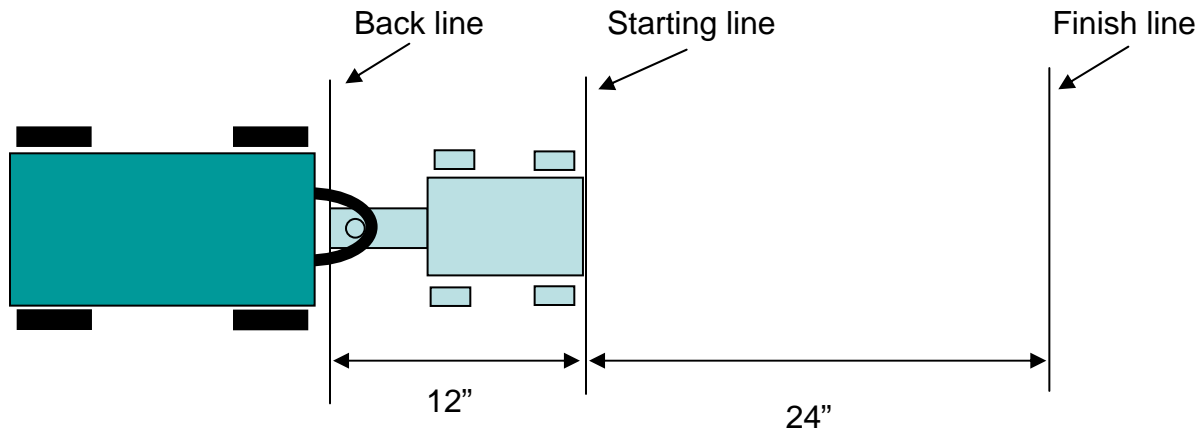
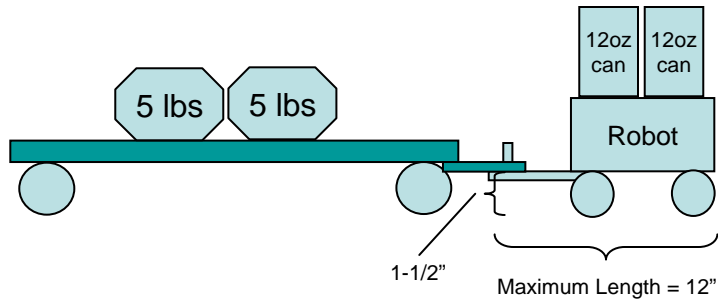

Event 5: Strongest Robot

- Connections have often been a problem for robots. Shown here is one simple, and strong method to connect to the cart:

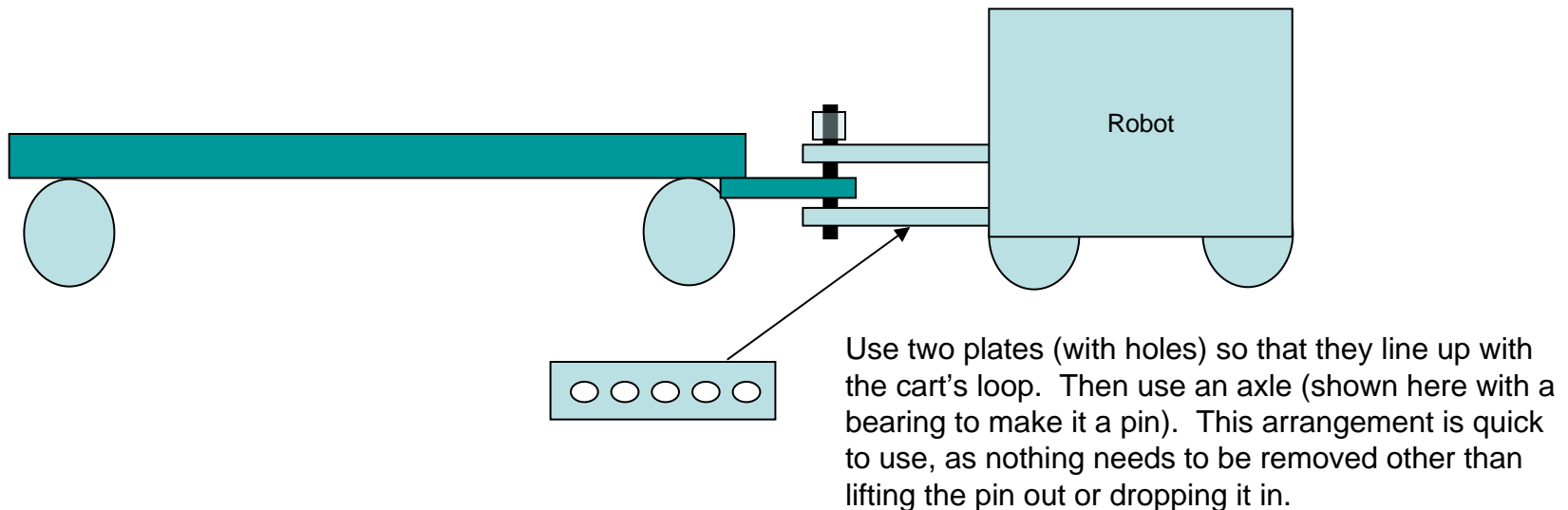

Changed!

Event 6: Bridge Building

- In this event teams build a bridge completely of LEGOs without any electronic components. This is an engineering event not a robot event.
- Any non-electric LEGO parts are acceptable for this event except for string, elastics, wires, and hoses.
- **The bridge must span 80 knobs (about 25 inches)**
- The supports must be 24 knobs or greater off the surface of the table/floor or other supporting surface.
- The bridge must have a surface at the center of the bridge at least 48 knobs long and 24 knobs wide for placement of weights on the bridge.
 - The surface must be “paved” or otherwise constructed to actually hold the loads intended.
 - The surface must be accessible for loading from above
 - Since bridges can be loaded (in theory) with up to 60 pounds, consider how large a volume this would require and build accordingly.
 - The officials may disqualify a bridge if it is difficult or impossible to load additional weight without the load falling off.
 - The team may stop at any weight to preserve the bridge from destructive testing, however, that would constitute a failure to continue (unless they are the only team left competing).
- Since the bridge may not use string or elastics as a part of the bridge it is expected that bridges will not be of the suspension variety. If there are any questions about this contact Maine Robotics for clarification.
 - The following websites have a good introduction to bridge design and principles.
<http://www.howstuffworks.com/bridge.htm>
<http://en.wikipedia.org/wiki/Bridge>
- All weight loading is done by Maine Robotics personnel.
- Support structures at the end of the span are provided and are 24 knobs wide and 6 knobs deep (see diagram)
- The top of the support structures are at least 2 LEGO bricks high without any interference.
- A bridge end may attach to the support structure knob surface (top)
- A bridge end may overlap the first brick of the support structure only (see diagram).
- The span of the bridge may extend down beyond the 1 brick limit as long as AT THE SUPPORT and all AROUND THE SUPPORT it does not extend below the 1 brick limit.
 - The span, with all loads applied must not touch the surface (table/floor) below the supports.
 - If there is any question as to whether this is occurring a sheet of paper must be able to pass between the surface and the bridge span at all points **and all weights**.
- The support structures will be provided by Maine Robotics. You may bring your own for display, but the official supports will be used at the competition.
- Each bridge will be weighed at the beginning of the competition and again at the end of trials if necessary to determine the winner of any ties.
 - There is no weight limit to the bridges
 - In the event of a tie, the lightest bridge will be the winner
 - Weight is for the bridge only, not the support structures.
- **Each bridge will be tested until failure or 80 pounds**, whichever occurs first. Once a bridge has completed testing, the officials will move on to the next bridge. Additional weight may be added for non-competitive testing.
- In 2008 2 of the 7 bridges tested could hold 115 pounds of weight without breaking (the amount of weight we had on hand).
- **Gold Standard: Bridge can hold 50 pounds**

Event 6: Bridge Building

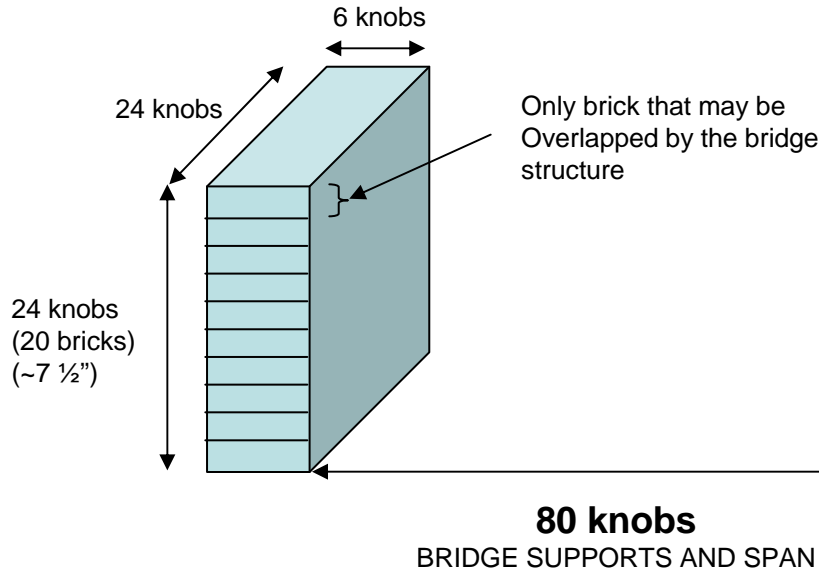

Note: The support structures may be built Differently than shown here. However, any Alterations may not affect the inside span, The top surface, or the top two bricks of the Support.

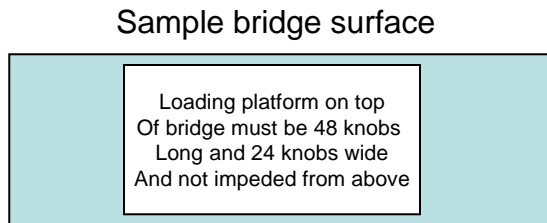

Keep in mind that the officials and teams must load the Bridge with up to 80 pounds of weight (12 five-pound bags Of flour or equivalent)

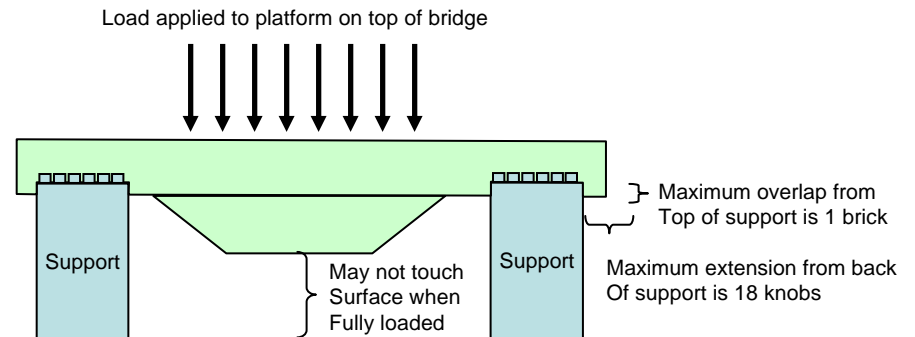

The central portion of the bridge may extend beyond the One brick support restriction, however at all points around The support, the overlap may not exceed 1 brick.

Event 6: Bridge Building

- The bridge building event is designed to focus on the following:
 - Compression and Tension
 - Force, mass, weight, and gravity
 - Comparative strengths of architectural design
 - Stress and torsion
- It is also included as a non-robot event, allowing a team with limited electronic components to compete in an additional event.

Event 6: Bridge Building - Stresses:

- **Compression** is the decrease in volume of an object when compressive stress is applied to the object. Different materials have different compressive characteristics. For example concrete has a very high compressive strength, but when exceeded results in structural failure. Steel also has a high compressive strength, but when exceeded results in buckling.
- **Tension** is the opposite of compression where tensile force is being applied to stretch an object. The tensile stress is the amount of force and the tensile strength is the amount of force that the material can be subjected to without failing. Failure is usually represented by breaking, although it could also be a certain limit you do not want exceeded. Rope, wire, and chain are all good examples of materials that have tensile strength but no compressive strength. Steel and wood have tensile strength AND compressive strength.
- **Shear** is the ability of an object to resist two forces in opposing directions applied against an object. Scissors work by shearing against an object. There is usually no change in volume of the object, but rather a displacement of the material. The earth's crust often has earthquakes when shear occurs in a plate.
- **Torsion** is the twisting of force around the axle of a material. Axles must withstand a great deal of torsional force without failing, otherwise they would break. Bolts are another example; if you over tighten a bolt with a wrench you may cause the bolt to fail by exceeding its torsion strength.
- **Elasticity** is the ability of a material to change shape and return to its original shape after the forces have been removed. Rubber is an easy example, but steel, glass, plastics and wood all have elasticity. Imagine a tree that couldn't bend? Or steel springs that didn't bounce?
- **Plastic deformation** is the result of material that is compressed/stretched/twisted beyond its limit of elasticity and you end up with permanent deformation (without outright structural failure).
- The Wikipedia has a good section on the strength of materials at http://en.wikipedia.org/wiki/Strength_of_materials.

Changed!

Event 7: Ping Pong Shot Put

- The Ping Pong Shot Put event is designed as an overall robot design project
 - Development of a system of components that can accomplish a task.
 - Non-mobile robot (robot base doesn't move)
 - Delivery of objects (ping pong balls) to a container.

Changed!

Event 7: Shot Put layout

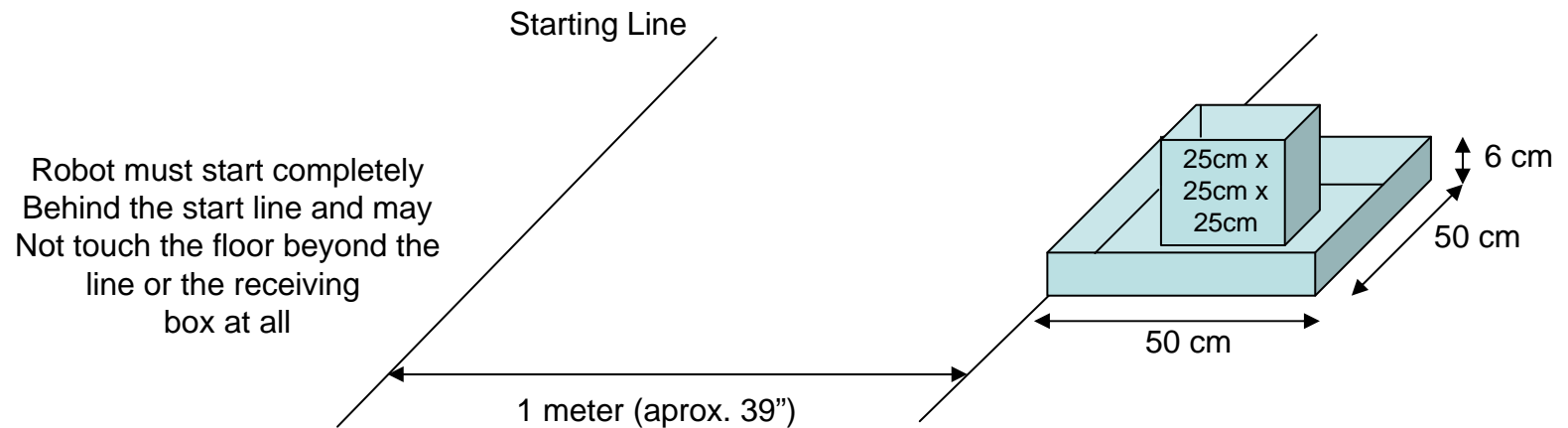

Changed!

Event 7: Shot Put layout

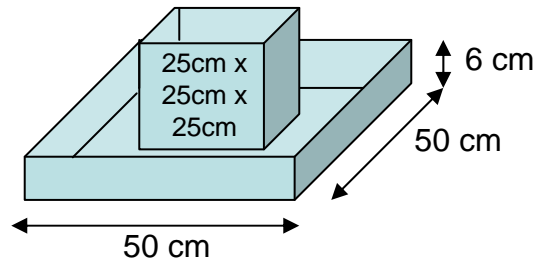

Receiving box-low:

1 point for each ball delivered

4 sides
50 cm on a side
Made from 3/16" (5 mm)
White foam board.
Taped on all sides.
Floor inside box will be lined
with felt sheets, cut to fit.

Attached directly to floor or
table

Receiving box-high:

3 points for each ball delivered

4 sides, and bottom.
25 cm on a side
Made from 3/16" (5 mm)
White foam board.
Taped on all sides.

The bottom will have a
Piece of cloth or foam to
Prevent "bounce-out" of
Delivered balls. It must be
confined to the
Bottom inch of the box.

The box is secured lightly
To the floor with tape to
Prevent minor movement.

Changed!

Event 7: Shot Put

- The robot must not touch the ground beyond the start line
- Any arm or extension that extends beyond the start line must be completely retracted behind the start line between delivery attempts (1 ball per extension)
- The robot may not touch the receiving boxes
- If a ball becomes “lost” it may be retrieved by the team and reused.
- The balls may be thrown, bounced, or dropped into the receiving box
- The robot must start completely behind the start line
- For the purposes of the meet we will be supplying the trials with 30 ping pong balls for delivery. If after practice you believe your robot can deliver more, please bring a supply with you for use at the meet.
- NOTE: Starting in 2009, the limit on “only one ball in delivery at a time” has been removed, except as noted for “extended” components above.
- NOTE: Starting in 2009, the distance to the receiving boxes has been shortened from 48” to 1 meter. However, the distance to the “high” receiving box is still approximately 44” (112.5 cm)
- Ping pong balls are loaded on the robot prior to starting a trial. However as the loading mechanism is emptied more balls may be added provided the team members do not touch the robot or affect its behavior
 - It is advantageous for a team to make some form of “ball hopper” to hold the balls for reloading
 - There is no limit to the number of balls held by the robot
- Teams will have a standard
 - “on your mark”
 - “get set”
 - “go” to begin
- Each trial:
 - will be for 30 seconds from “go”
 - at the end of 30 seconds scoring will be the number of ping pong balls in the receiving boxes.
 - If a ball is in delivery at the end of the trial’s 30 seconds, but not yet delivered it will not count.
 - Each ball delivered to the low receiving box will earn 1 point
 - Each ball delivered to the high receiving box will earn 3 points.

Changed!

Event 8: Robot Speed Build

- We've added this event to provide additional opportunity for the contestants to show off building skills without tying up your robots on competition day
- This event uses a prescribed set of parts in a container on a table (provided by Maine Robotics).
 - Several extra bushings and black connectors will be in each container just in case some go walk-about. Competitors must inform officials if there are parts missing PRIOR to the start of the trial, so check quickly.
- Each contestant starts building the TreadBot or the Simple NXT Robot at the beginning of the match
- A contestants time is to when they are finished building the robot and it runs program #1 (RCX) or "forward" (NXT) on the robot (move forward aprox. 1 foot)
- Each contestant will have two trials to get the fastest and most successful build
- The best of the two trials will be used for the winning ranking in each of the two divisions (NXT and RCX)

Changed!

Event 8: Robot Speed Build

- Directions for the TreadBot and the Simple NXT Robot can be found at www.mainerobotics.org/trackmeet.html
- NOTE: The robots will be programmed ahead of time to drive forward IF you have placed the motor wires as follows (different from image in on-line diagrams):
 - For RCX TreadBot
 - On RCX
 - attach to motor ports A and C
 - Have wire leading back from connection (away from IR window)
 - On Motor
 - Have wire leading back from RCX (away from the main body of the RCX)
 - For NXT Simple NXT Robot
 - Connect motors to motor ports B and C (default)

Changed!

Event 8: Robot Speed Build

- Robot must be completely built
- Robot must be built according to the specs in the online documents
- Robot must be able to drive forward using program 1 (RCX) or “forward” (NXT)
- All parts must be completely disassembled prior to the start of the round
- Contestants may layout their parts prior to the start of the round (a one minute time will be allowed for setup)
- Each round will consist of:
 - 1 minute setup (contestant may arrange, but not connect parts)
 - 6 minute build and run

Changed!

Event 8: Robot Speed Build

- We've been building these robots here at Maine Robotics for some time now and we've timed ourselves. We can build either the TreadBot or the Simple NXT Robot in around 3:00 minutes. In our favor is that we've got LOTS of experience building; and against us is that we're getting older and move slower.
- For 2009 we will have an NXT winner and an RCX winner, but they will be racing together.
- This will be the last year for the RCX TreadBot, fair warning it will be gone by 2010.

Notes from the Director

- As with all activities it may be necessary to find people to help out. Someone with carpentry skills can easily make the playing field elements.
- Bricklink.com is an excellent source of spare parts (or to sell spare parts)
- And remember, if you aren't having fun, then you and your team are missing out!